

2'-6" CURB AND GUTTER

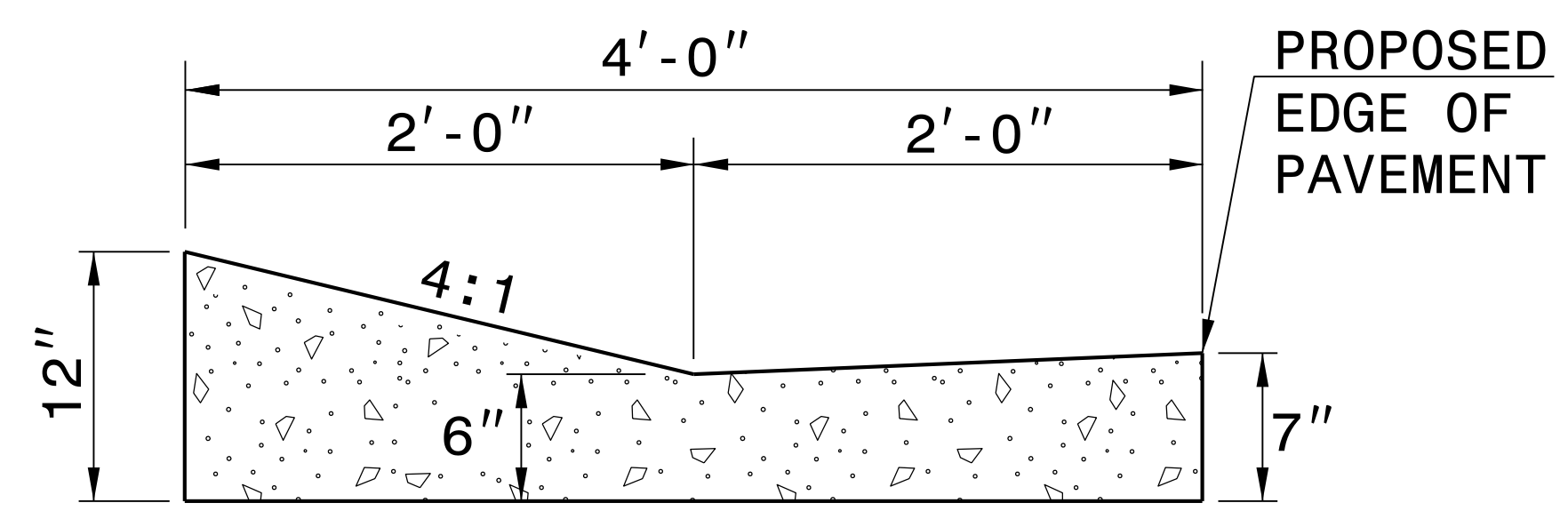

EXPRESSWAY GUTTER

NOTE: SEE STD. DWG. 846.01 FOR ADDITIONAL CURB AND GUTTER INFORMATION.
SEE ROADWAY PLANS FOR LOCATION OF CURB TRANSITION.

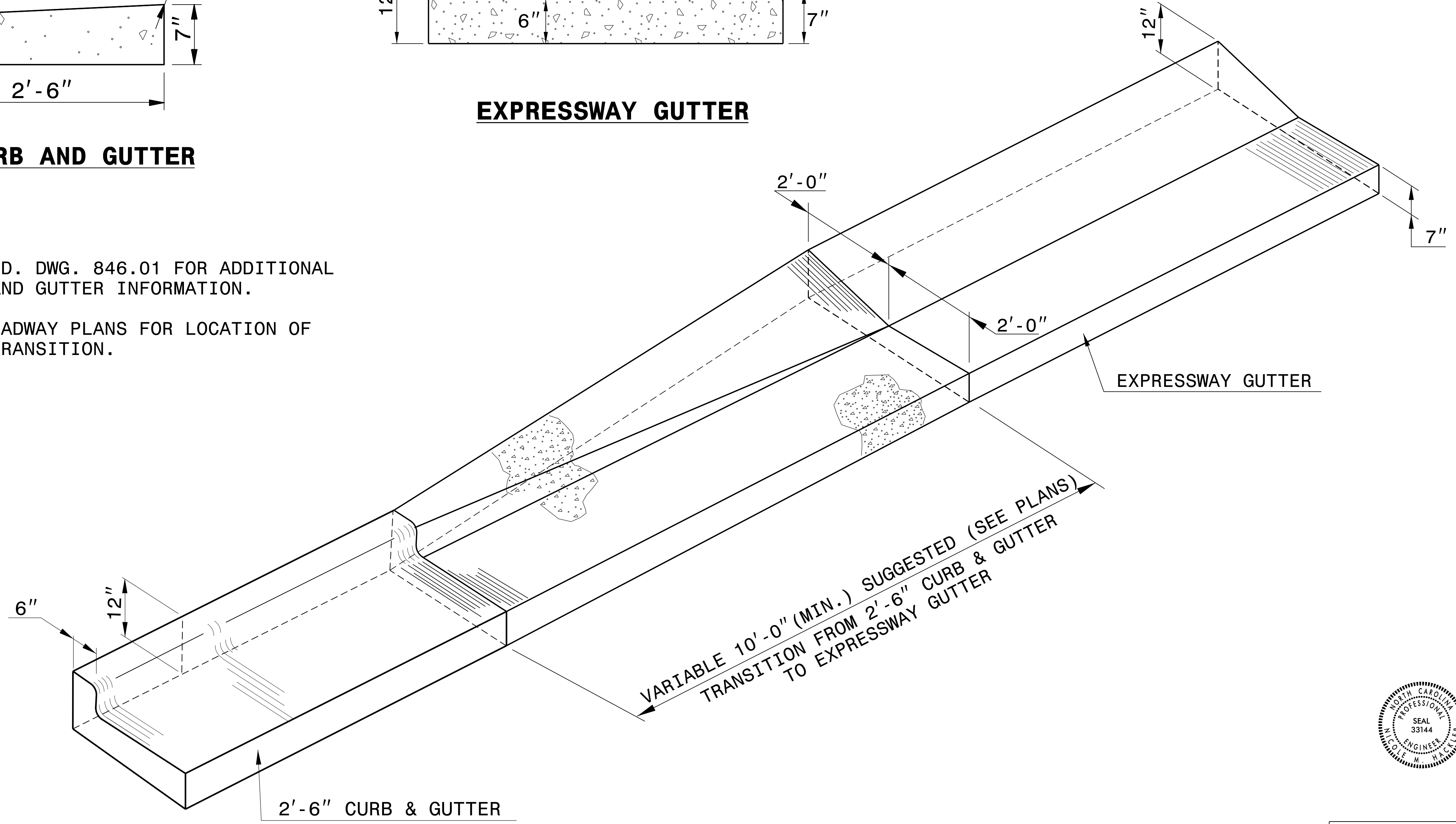

ISOMETRIC VIEW OF TRANSITION

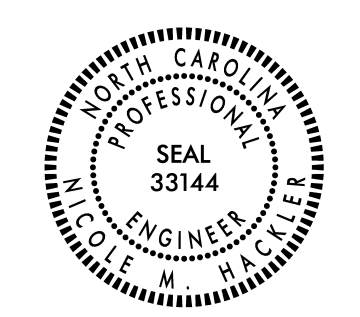

DOCUMENT NOT CONSIDERED FINAL UNLESS ALL SIGNATURES COMPLETED

| | |
|--|------------------|
| CONTRACT STANDARDS AND DEVELOPMENT UNIT | |
| Office 919-707-6950 | FAX 919-250-4119 |
| DETAIL OF 2'-6" CURB & GUTTER TO EXPRESSWAY GUTTER TRANSITION SECTION | |
| ORIGINAL BY: T.S.Spell | DATE: 8-13-02 |
| MODIFIED BY: | DATE: |
| CHECKED BY: | DATE: |
| FILE SPEC.: w:usr/details/stand/cgtransit.dgn | |

5/14/99
05-OCT-2017 08:23
S:\Contracts\Contractors\Special Details\Vericard\usr\details\stand\c&g transition sections.dgn
Jhewerton AT USD-292595